

MODEL NO.: TST070JDHG30-00
ISSUED DATE: 2017-06-23
VERSION : Ver 1.0

- Preliminary Specification
- Final Product Specification

Customer :

Approved by	Note

TSD Confirmed :

Prepared by	Checked by	Approved by
Aron		

This technical specification is subjected to change without notice.



Table of Contents

1. General Specifications	4
2. Input/Output Terminals.....	5
2.1 TFT CN1 pin assignment.....	5
3. Absolute Maximum Ratings	6
4. Electrical Characteristics.....	6
4.1 Driving TFT LCD Panel.....	6
4.2 TFT Driving Backlight.....	7
4.3 TFT Block Diagram.....	8
5. Timing Chart	9
5.1 AC Electrical Characteristics	9
5.2 DC Electrical Characteristics.....	9
5.3 Input Timing	11
5.4 Data Input Format.....	11
5.5 Power On/Off Timing.....	12
6. Optical Characteristics	14
7. Reliability Test	17
8. Mechanical Drawing	19
9. Precautions for Use of LCD Modules.....	20



Record of Revision

Rev	Issued Date	Description	Editor
1.0	2017-06-23	First release	Aron

1 General Specification

Item	Feature	Spec	Unit
TFT	Size	7	inch
	Resolution	1280(RGB) x 800	--
	Interface	LVDS	--
	Color Depth	16.7M	--
	Technology Type	a-Si	--
	Pixel Pitch	0.117(H) x 0.117 (V)	mm
	Pixel Configuration	R.G.B. Vertical Stripe	--
	Display Mode	SFT with Normally Black	--
	Surface Treatment(Up Polarizer)	HC	--
	LCM (W x H x D)	161.0×107.0×3.15	mm
Mechanical Characteristics	LED Numbers	21 LEDs	--
	Weight	TBD	g
	Operation temperature	-20~70	°C
	Storage temperature	-30~80	°C
Electrical Characteristics	Interface	LVDS 40 Pin	
	Driver IC	3*ST5821C and 1*ST5084C	

Note 1: Requirements on Environmental Protection: Q/S0002

2. Input/output Terminals

2.1 TFT CN1 pin assignment Connector type: Molex 54132-4062

Pin No.	Symbol	I/O	function	Remarks
1	NC	--	No connection	
2	VDD	P	Power Voltage for digital circuit	
3	VDD	P	Power Voltage for digital circuit	
4	NC	--	No connection	
5	NC	--	No connection	
6	NC	--	No connection	
7	GND	P	Ground	
8	RXIN0-	I	- LVDS differential data input	
9	RXIN0+	I	+LVDS differential data input	
10	GND	P	Ground	
11	RXIN1-	I	-LVDS differential data input	
12	RXIN1+	I	+LVDS differential data input	
13	GND	P	Ground	
14	RXIN2-	I	-LVDS differential data input	
15	RXIN2+	I	+LVDS differential data input	
16	GND	P	Ground	
17	RXCLKIN-	I	-LVDS differential clock input	
18	RXCLKIN+	I	+LVDS differential clock input	
19	GND	P	Ground	
20	RXIN3-	I	-LVDS differential data input	
21	RXIN3+	I	+LVDS differential data input	
22	GND	P	Ground	
23	NC	--	No connection	
24	NC	--	No connection	
25	GND	P	Ground	
26	NC	--	No connection	
27	NC	--	No connection	
28	NC	--	No connection	
29	AVDD	P	Power for Analog Circuit	
30	GND	P	Ground	
31	LED-	P	LED Cathode	
32	LED-	P	LED Cathode	
33	NC	--	No connection	
34	NC	--	No connection	
35	VGL	P	Gate OFF Voltage	
36	NC	--	No connection	
37	NC	--	No connection	
38	VGH	P	Gate ON Voltage	
39	LED+	P	LED Anode	
40	LED+	P	LED Anode	

Note1: I/O definition.
 I---Input, O---Output, P--- Power/Ground, N--- No connection

3. Absolute Maximum Ratings

GND=0V, Ta = 25°C

Item	Symbol	Min	Max	Unit	Remark
Power Voltage	VDD	-0.5	5.0	V	
	AVDD	-0.5	14.85	V	
	VGH	-0.3	20.0	V	
	VGL	-20.0	0.3	V	
Backlight Forward Current	I _{LED}	—	25	mA	For each LED
Operating Temperature	T _{OPR}	-20	70	°C	
Storage Temperature	T _{STG}	-30	80	°C	

Table 3.1 absolute maximum rating

4 Electrical Characteristics

4.1 Driving TFT LCD Panel

Ta = 25°C

Item	Symbol	Min	Typ	Max	Unit	Remark
Digital Supply Voltage	VDD	3.0	3.3	3.6	V	
Analog Supply Voltage	AVDD	10.5	11	11.5	V	
Gate On Voltage	VGH	17.5	18.0	18.5	V	
Gate Off Voltage	VGL	-7.1	-6.8	-6.5	V	
Common Electrode Driving Signal	VCOM	3.45	3.55	3.65	V	With the VR Knob

Table 4.1 LCD module electrical characteristics

4.2 TFT Driving Backlight

Item	Symbol	Condition	Min	Typ	Max	Unit	Remark
Forward Voltage	VLED	$I_F=140\text{mA}$	--	9.3	10.2	V	Note 1 Note 2
Forward Current	I_F	-	-	140	-	mA	
Backlight Power Consumption	WBL	$I_F=140\text{mA}$	--	1302	1428	mW	
Life Time	-	$I_F=140\text{mA}$	--	30,000-	-	Hrs	Note 3

Table 4.2 LED backlight characteristics

Note 1: I_F is defined for one channel LED. There are total three LED channels in back light unit. Under LCM operating, the stable forward current should be inputted.

Note 2: Optical performance should be evaluated at $T_a=25^\circ\text{C}$ only.

Note 3: If LED is driven by high current, high ambient temperature & humidity condition. The life time of LED will be reduced. Operating life means brightness goes down to 50% initial brightness. Typical operating life time is estimated data.

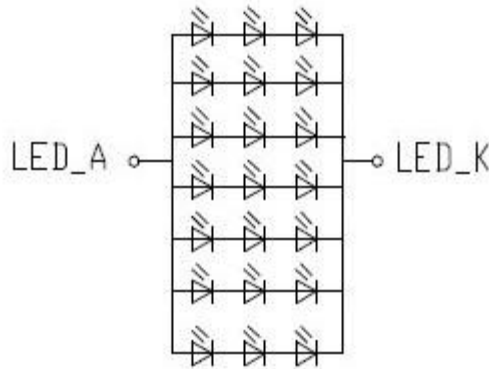

LED circuit
 $V_f=9.3\text{V}$, $I_f=140\text{mA}$

Figure 4.1 LED connection of backlight

4.3 TFT Block Diagram

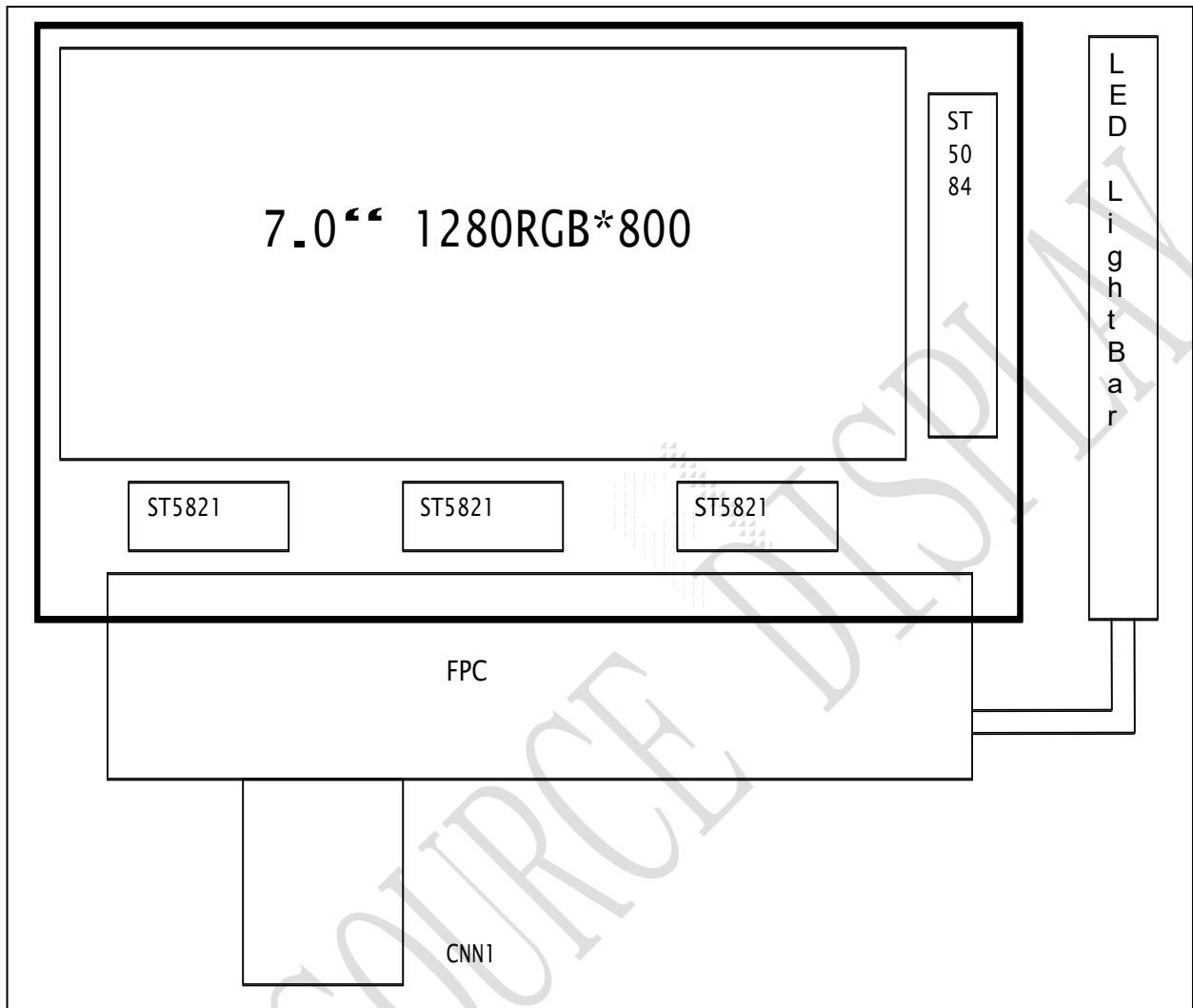
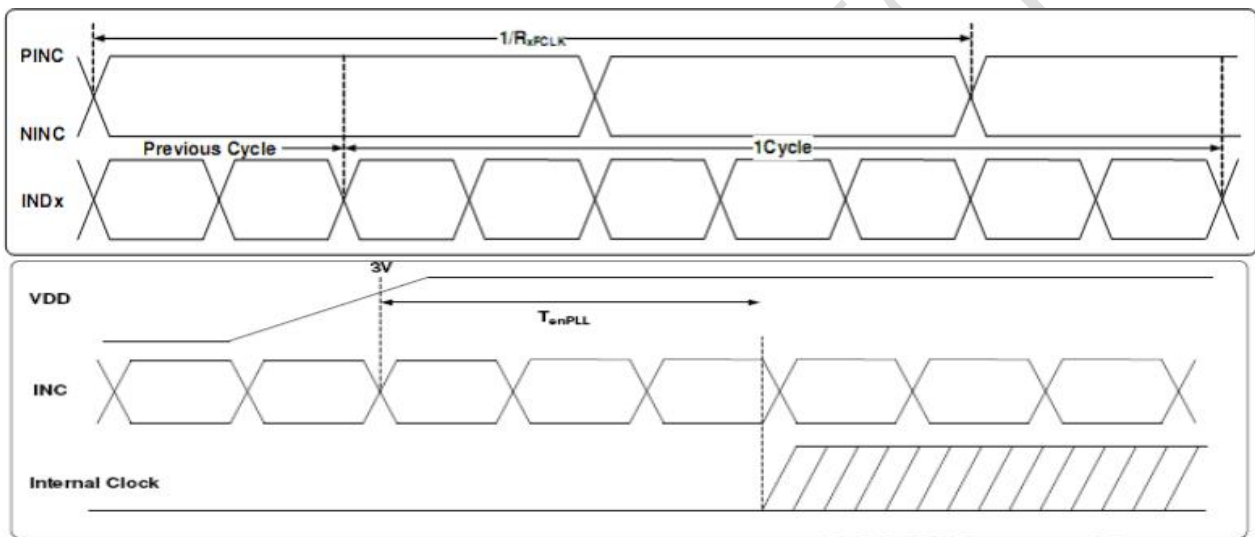

Figure 4.3 TFT Block Diagram

5. Timing Chart

5.1 AC Electrical Characteristics

Parameter	Symbol	Min	Typ	Max	Unit	Conditions
Clock Frequency	R_{XFCLK}	20	-	80	MHz	
Input data skew margin	T_{RSKM}	500	—	—	ps	$ V_{ID} = 400mV$, $R_{XVCM} = 1.2V$ $R_{XFCLK} = 80MHz$
Clock high time	T_{LVCH}	—	4/7	—	R_{XFCLK}	
Clock low time	T_{LVCL}	—	3/7	—	R_{XFCLK}	
PLL wake-up time	T_{enPLL}	—	—	150	us	



5.2 DC Electrical Characteristics

$V_{GH} = 18V$, $V_{GL} = -7V$, $V_{DD} = 3.3V$, $GND = 0V$, $T_a = 25^\circ C$

Parameter	Symbol	Min	Typ	Max	Unit	Remark
Differential input high Threshold voltage	R_{XVTH}	-	-	+0.1	V	
Differential input Low Threshold voltage	R_{XVTL}	-0.1	-	-	V	
Input voltage range	R_{XVIN}	0	-	$V_{DD} - 1.0$	V	
Differential input common Mode voltage	R_{XVCM}	$ V_{ID} /2$	-	$2.4 - V_{ID} /2$	V	
Differential input voltage	$ V_{ID} $	0.2	v	0.6	V	

Differential input leakage Current	$R_{V_{XIZ}}$	-10	v	+10	uA	
LVDS Digital Operating Current	I_{ddlvds}	-	~ 40	~ 50	mA	Fclk=65MHz, VDD=3.3V
LVDS Digital Stand-by Current	I_{stlvds}	-	~ 10	~ 50	uA	Clock & all functions are stopped

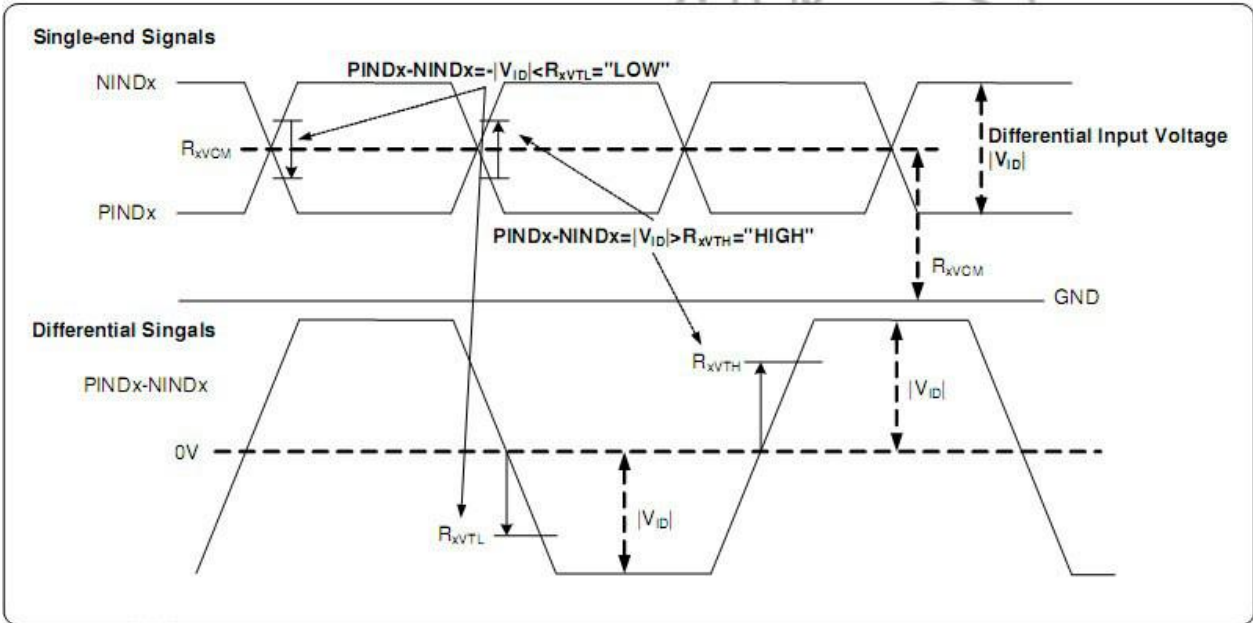

5.3 Input timing

1280x800 (RES[3:0] = 0010)

Parameter	Symbol	Value			Unit	Note
		Min.	Typ.	Max.		
CLK frequency	t _{CLK}	62.6	68.2	78.1	Mhz	
Horizontal blanking time	t _{HBT}	20	69	164	t _{CLK}	t _{HBP} + t _{HFP}
Horizontal back porch	t _{HBP}	5	5	164 - t _{HFP}	t _{CLK}	
Horizontal display area	t _{HD}	1280	1280	1280	t _{CLK}	
Horizontal front porch	t _{HFP}	15	64	159	t _{CLK}	
Horizontal period	t _H	1300	1349	1444	t _{CLK}	
Horizontal pulse width	t _{HPW}	1	1	256	t _{CLK}	
Vertical blanking time	t _{VBT}	5	42	101	t _H	t _{VBP} + t _{VFP}
Vertical back porch	t _{VBP}	2	2	101 - t _{VFP}	t _H	
Vertical display area	t _{VD}	800	800	800	t _H	
Vertical front porch	t _{VFP}	3	40	99	t _H	
Vertical period	t _V	803	842	901	t _H	
Vertical pulse width	t _{VPW}	1	1	128	t _H	

5.4 Data Input Format

VESA data mapping

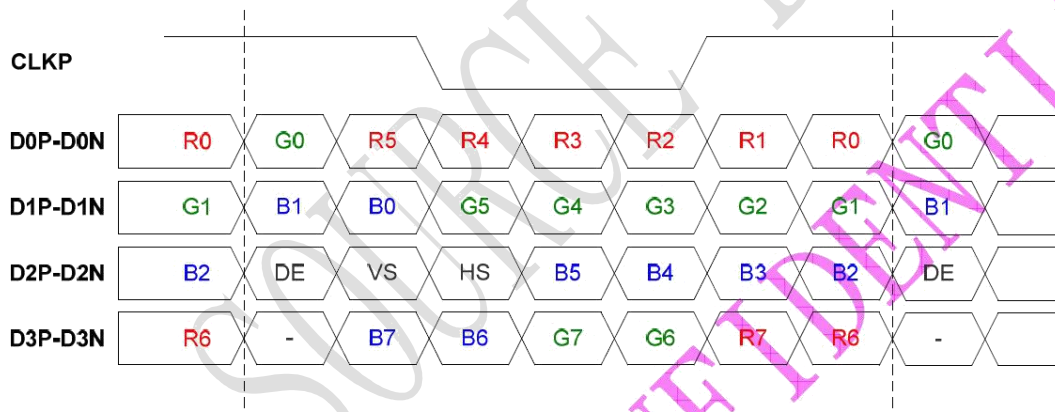

Note 1 : for 6 bit mode, MSB are R/G/B[5] and R/G/B[0] are LSB
 Note 2 : for 8 bit mode, MSB are R/G/B[7] and R/G/B[0] are LSB

JEIDA data mapping



5.5 Power On/Off Timing

To prevent the device damage from latch up, the power on/off sequence shown below must be followed.

Power ON:

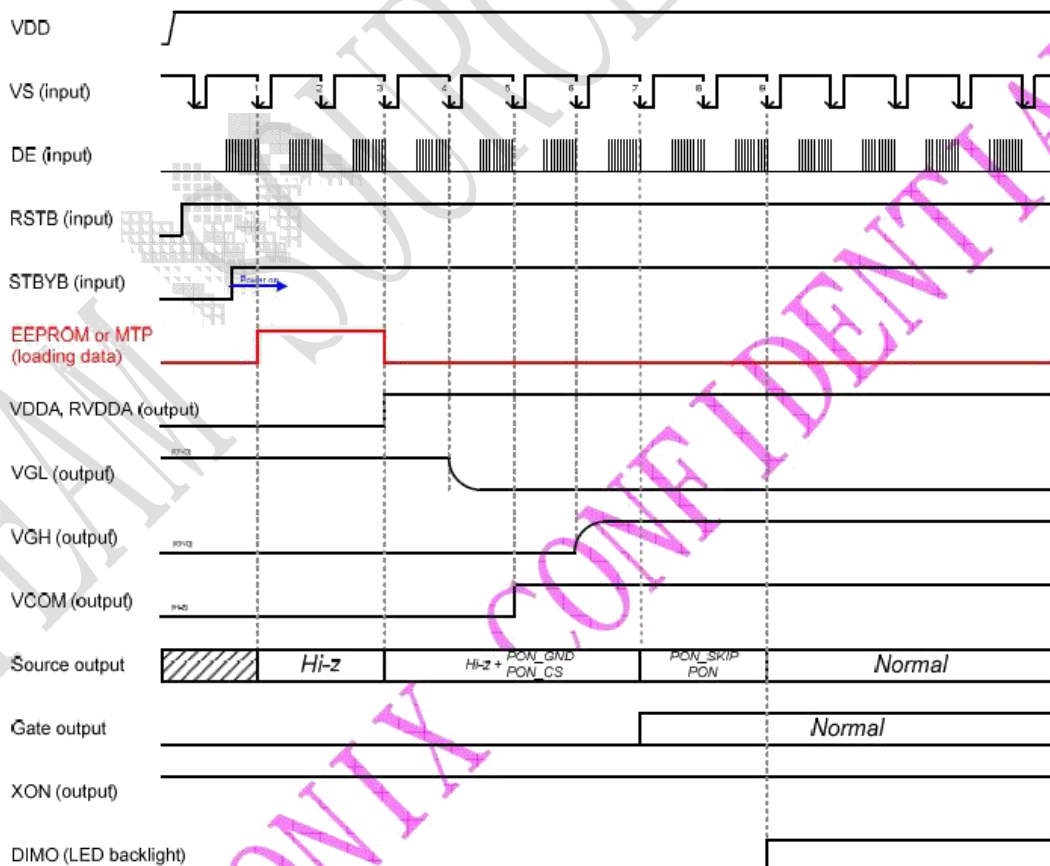

Power Off:

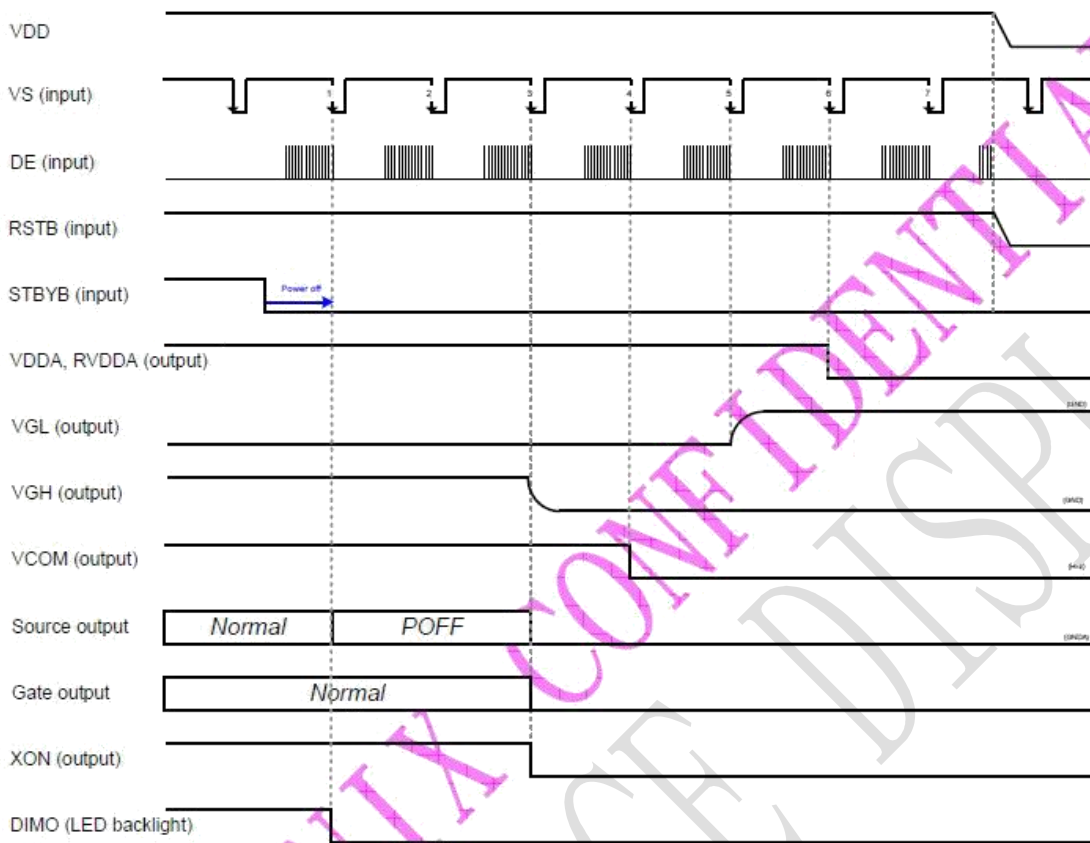

.6. Optical Characteristics

6.1 TFT Optical Characteristics

Item	Symbol	Condition	Min	Typ	Max	Unit	Remark
View Angles	θT	$CR \geq 10$	80	88	-	Degree	Note 2
	θB		80	88	-		
	θL		80	88	-		
	θR		80	88	-		
Contrast Ratio	CR	$\theta=0^\circ$	600	800	-		Left/right 0° Top/bottom 5°
Response Time	T_{ON}	25°C	-	35	40	ms	Note1
	T_{OFF}						Note4
Chromaticity	White	x	0.256	0.306	0.356		Note5 Note1
		y	0.279	0.329	0.379		
	Red	x	0.520	0.570	0.620		
		y	0.280	0.330	0.380		
	Green	x	0.300	0.350	0.400		
		y	0.542	0.592	0.642		
	Blue	x	0.105	0.155	0.205		
		y	0.051	0.101	0.151		
Uniformity	U		70	75	-	%	Note1 ! Note6
NTSC			45	50	-	%	
Luminance	L		320	400	-	cd/m ²	Note7

Test Conditions:

1. $I_F = 20mA$ (one channel), the ambient temperature is 25°C.
2. The test systems refer to Note 1 and Note 2.

Note 1: Definition of optical measurement system.

The optical characteristics should be measured in dark room. After 10 Minutes operation, the optical properties are measured at the center point of the LCD screen. All input terminals LCD panel must be ground when measuring the center area of the panel.

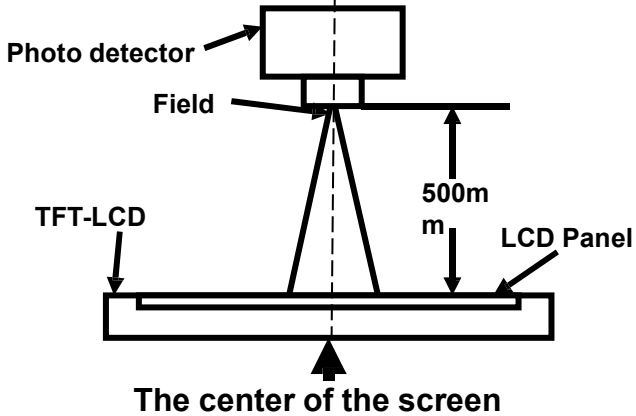

Item	Photo detector	Field
Contrast Ratio	SR-3A	1°
Luminance		
Chromaticity		
Lum Uniformity		
Response Time	BM-7A	2°

Note 2: Definition of viewing angle range and measurement system.

viewing angle is measured at the center point of the LCD by CONOSCOPE(ergo-80)DŽ

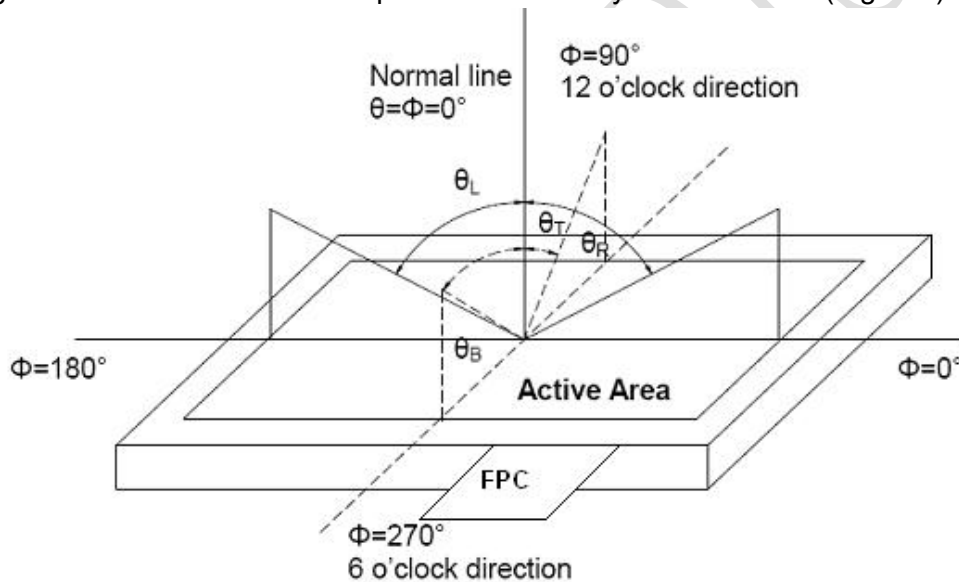

Note 3: Definition of contrast ratio

“White state “: The state is that the LCD should drive by V_{white} .

“Black state“: The state is that the LCD should drive by V_{black} .

V_{white} : To be determined V_{black} : To be determined.

Note 4: Definition of Response time

The response time is defined as the LCD optical switching time interval between “White” state and “Black” state. Rise time (T_{ON}) is the time between photo detector output intensity changed from 90% to 10%. And fall time (T_{OFF}) is the time between photo detector output intensity changed from 10% to 90%.

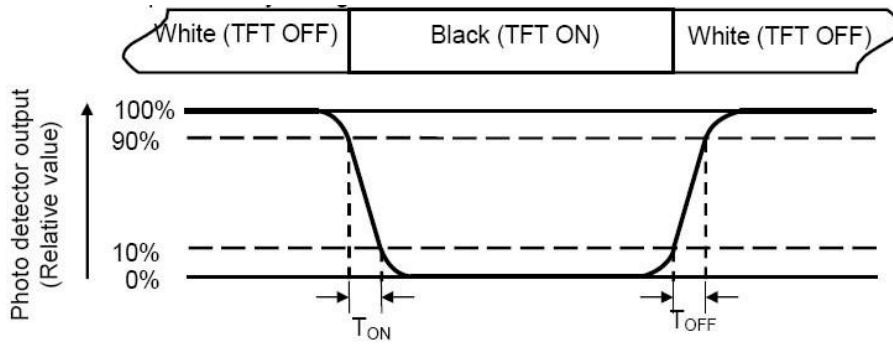

Note 5: Definition of color chromaticity (CIE1931)
 Color coordinates measured at center point of LCD.

Note 6: Definition of Luminance Uniformity

Active area is divided into 9 measuring areas (Refer Fig. 2). Every measuring point is placed at the center of each measuring area.

$$\text{Luminance Uniformity (U)} = \text{Lmin} / \text{Lmax}$$

L-----Active area length W----- Active area width

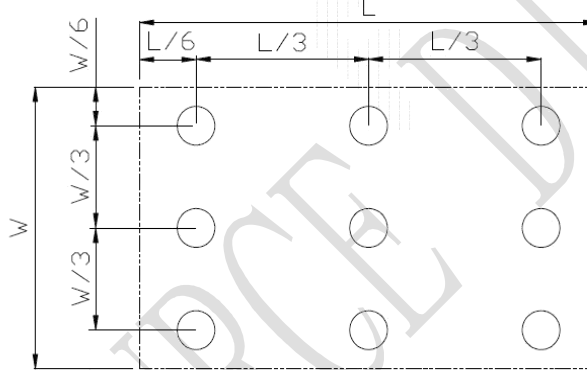

Lmax: The measured Maximum luminance of all measurement position.

Lmin: The measured Minimum luminance of all measurement position.

Note 7: Definition of Luminance:

Measure the luminance of white state at center point.

7. Reliability Test

No	Test Item	Condition	Remarks
1	High Temperature Operation	Ta = +70°C, 240 hours	IEC60068-2-1:2007 GB2423.2-2008
2	Low Temperature Operation	Ta = -20°C, 240 hours	IEC60068-2-1:2007 GB2423.1-2008
3	High Temperature Storage	Ta = +80°C, 240 hours	IEC60068-2-1:2007 GB2423.2-2008
4	Low Temperature Storage	Ta = -30°C, 240 hours	IEC60068-2-1:2007 GB2423.1-2008
5	Storage at High Temperature and Humidity	Ta=+60°C、RH=90%, 240 hours	IEC60068-2-78 :2001 GB/T2423.3—2006
6	Thermal Shock (non-operation)	-30°C ^ 30min √ ⇔ 80°C ^ 30min √ ,Change Time:5min,20cycle	Start with cold temperature, End with high temperature, IEC60068-2-14:1984,G B2423.22-2002
7	ESD	C=150pF、R=330Ω Air: ±8KV Contact:±4KV 5point/panel, 5times (Environment:15°C~35°C, 30%~60%.86Kpa~106Kpa)	IEC61000-4-2:2001 GB/T17626.2-2006
8	Vibration Test	Frequency range:10~55Hz Stroke: 1.5mm Sweep: 10Hz~55Hz~10Hz 2 hours for each direction of X.Y.Z. (6 hours for total)	IEC60068-2-6:1982 GB/T2423.10—1995
9	Mechanical Shock (Non OP)	Half Sine Wave 60G ,6ms,±X,±Y,±Z 3times for each direction	IEC60068-2-27:1987 GB/T2423.5—1995
10	Package Drop Test	Height:60cm, 1corner,3edges,6surfaces	IEC60068-2-32:1990 GB/T2423.8—1995

Notes:

1. The test result shall be evaluated after the sample has been left at room temperature and humidity for 2 hours without load. No condensation shall be accepted. The sample will not be accepted if appear these defects:

- 1).Air bubble in the LCD;
- 2).Seal leak
- 3).Non-display
- 4).missing segments
- 5).Glass crack
- 6).CR reduction >40%
- 7).IDD increase >100%
- 8).Brightness reduction >50%

- 9).Color coordinate tolerance >0.05
3. Each test item applies for a test sample only once, The test sample can not be used again in any other test item.
- 4.For Damp Proof Test, Pure water(Resistance > 10MΩ) should be used.
- 5.In case of malfunction defect caused by ESD damage, if it would be recovered to normal state after resetting, it would be judge as a good part.
- 6 In the test of High Temperature Operation and High Temperature & Humidity Operation ,the operation temperature is the surface temperature of module
- 7 High Temperature Operation ! Low Temperature Operation ! High Temperature Storage ! Low Temperature Storage ! High Temperature & Humidity Operation ! High Temperature & Humidity Storage will be increased the test time to 1000hours in the same conditions to test out the ability of module, and we can not guarantee that the module will not fail during 1000hours.These items test only once

8. Mechanical Drawing

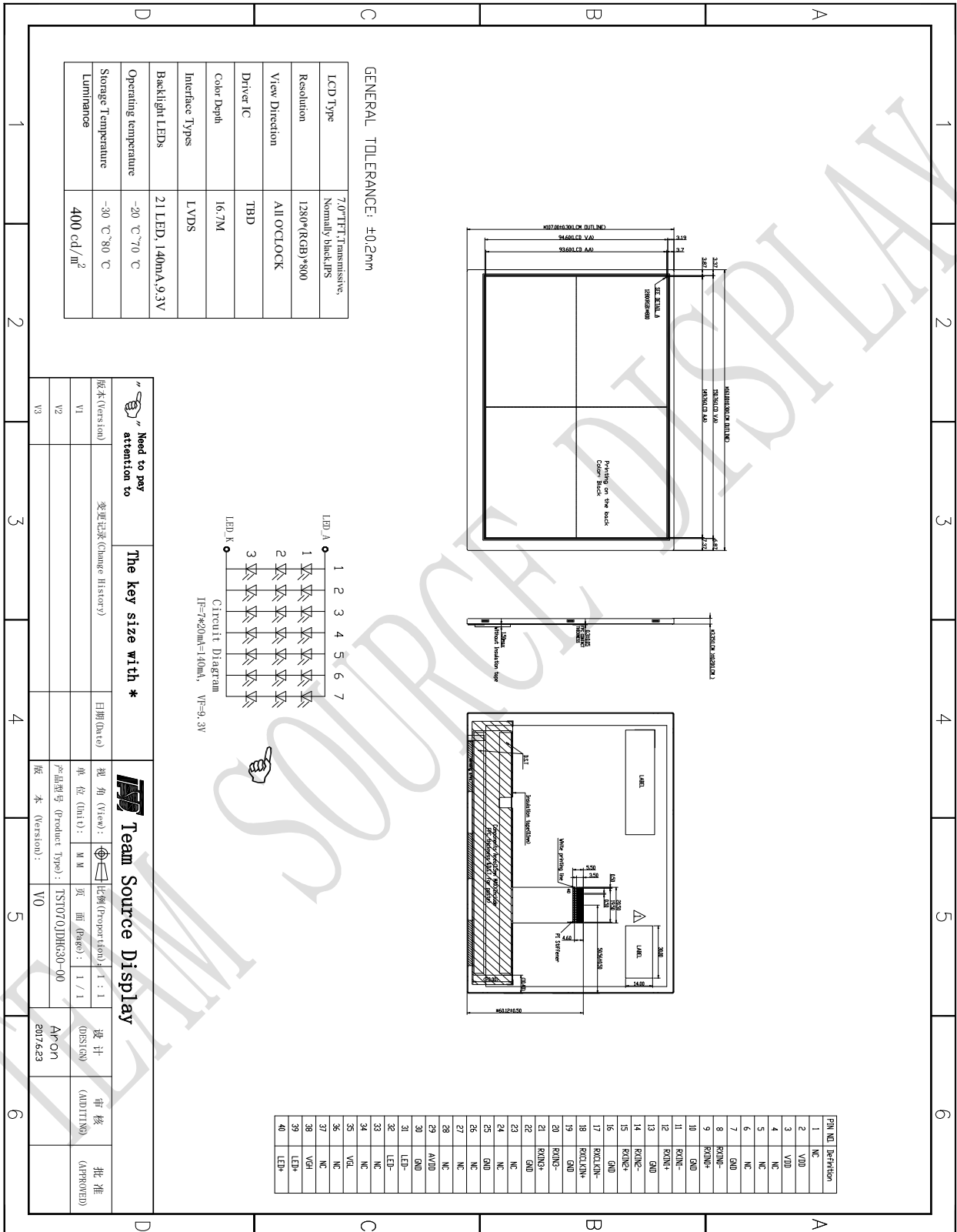

9. Precautions for Use of LCD Modules

9.1 Handling Precautions

- 9.1.1 The display panel is made of glass. Do not subject it to a mechanical shock by dropping it from a high place, etc.
- 9.1.2 If the display panel is damaged and the liquid crystal substance inside it leaks out, be sure not to get any in your mouth, if the substance comes into contact with your skin or clothes, promptly wash it off using soap and water.
- 9.1.3 Do not apply excessive force to the display surface or the adjoining areas since this may cause the color tone to vary.
- 9.1.4 The polarizer covering the display surface of the LCD module is soft and easily scratched. Handle this polarizer carefully.
- 9.1.5 If the display surface is contaminated, breathe on the surface and gently wipe it with a soft dry cloth. If still not completely clear, moisten cloth with one of the following solvents:
- Isopropyl alcohol
 - Ethyl alcohol
- Solvents other than those mentioned above may damage the polarizer.
Especially, do not use the following:
- Water
 - Ketone
 - Aromatic solvents
- 9.1.6 Do not attempt to disassemble the LCD Module.
- 9.1.7 If the logic circuit power is off, do not apply the input signals.
- 9.1.8 To prevent destruction of the elements by static electricity, be careful to maintain an optimum work environment.
- a. Be sure to ground the body when handling the LCD Modules.
 - b. Tools required for assembly, such as soldering irons, must be properly ground.
 - c. To reduce the amount of static electricity generated, do not conduct assembly and other work under dry conditions.
 - d. The LCD Module is coated with a film to protect the display surface. Be care when peeling off this protective film since static electricity may be generated.

9.2 Storage precautions

9.2.1 When storing the LCD modules, avoid exposure to direct sunlight or to the light of fluorescent lamps.

9.2.2 The LCD modules should be stored under the storage temperature range. If the LCD modules will be stored for a long time, the recommend condition is:

Temperature : 0°C ~ 40°C

Relatively humidity: ≤80%

9.2.3 The LCD modules should be stored in the room without acid, alkali and harmful gas.

9.3 The LCD modules should be no falling and violent shocking during transportation, and also should avoid excessive press, water, damp and sunshine.