



一众显示科技有限公司

TEAM SOURCE DISPLAY TECH. CO, LTD.

# TFT-LCD Module Specification

**Module NO.:** TST035QVHS-119

**Version:** V1.1

APPROVAL FOR SPECIFICATION

APPROVAL FOR SAMPLE

For Customer' s Acceptance:	
Approved by	Comment

Team Source Display:		
Presented by	Reviewed by	Approved by

Version No.	Date	Content	Remark
V1.0	2023-4-28	Initial Release	
V1.1	2023-07-19	Modify interface	

# Contents

<b>1 GENERAL CHARACTERISTICS .....</b>	<b>- 3 -</b>
<b>2 PRODUCT DRAWINGS .....</b>	<b>- 4 -</b>
<b>3 INTERFACE DESCRIPTION .....</b>	<b>- 5 -</b>
3.1 LCM INTERFACE DESCRIPTION .....	- 5 -
<b>4 LCM INTERFACE TIMING AND POWER ON/OFF SEQUENCE .....</b>	<b>- 6 -</b>
4.1 RESET TIMING .....	- 6 -
4.2 RGB INTERFACE TIMING .....	- 7 -
4.3 POWER ON/OFF SEQUENCE .....	- 10 -
<b>5 ABSOLUTE MAXIMUM RATINGS .....</b>	<b>- 11 -</b>
<b>6 ELECTRICAL CHARACTERISTICS .....</b>	<b>- 11 -</b>
<b>7 BACKLIGHT CHARACTERISTICS .....</b>	<b>- 11 -</b>
<b>8 LCD OPTICAL SPECIFICATIONS .....</b>	<b>- 12 -</b>
<b>9 RELIABILITY TEST .....</b>	<b>- 14 -</b>
9.1 TEST CONDITION .....	- 14 -
9.2 ABOUT IMAGE STICKING .....	- 15 -
9.3 OTHERS .....	- 16 -
<b>10 SUGGESTIONS FOR USING LCD MODULES .....</b>	<b>- 16 -</b>
10.1 HANDLING OF LCM .....	- 16 -
10.2 STORAGE .....	- 17 -
<b>11 LIMITED WARRANTY .....</b>	<b>- 17 -</b>

## 1 General Characteristics

ITEM	Specification	Unit
LCD Type	a-Si TFT, Transmissive, Normally black, IPS	-
LCD Size	3.5	inch
Resolution	320 x (RGB) x 240	pixel
LCM (W x H x D)	76.9(W) x 63.9(H) x 3.05(D)	mm
Active Area (W x H)	70.08(W) x 52.56 (H)	mm
Dot size (W x H)	0.073*0.219	mm
Viewing Direction	ALL o'clock	-
Color Depth	16.7M	-
Pixel Arrangement	RGB-stripe	-
Backlight Type	6 LED, 20mA, 18.6V	-
Surface Luminance	900	cd/m <sup>2</sup>
Surface Treatment	Clear	-
Driver IC	ST7272A	-
Interface Type	RGB24-bit	-
Input Voltage	3.3	V
TP/Lens	Without	-
Weight	TBD	g

**Note 1: RoHS compliant**

**Note 2: LCM weight tolerance: ± 5%.**

## 2 Product drawings

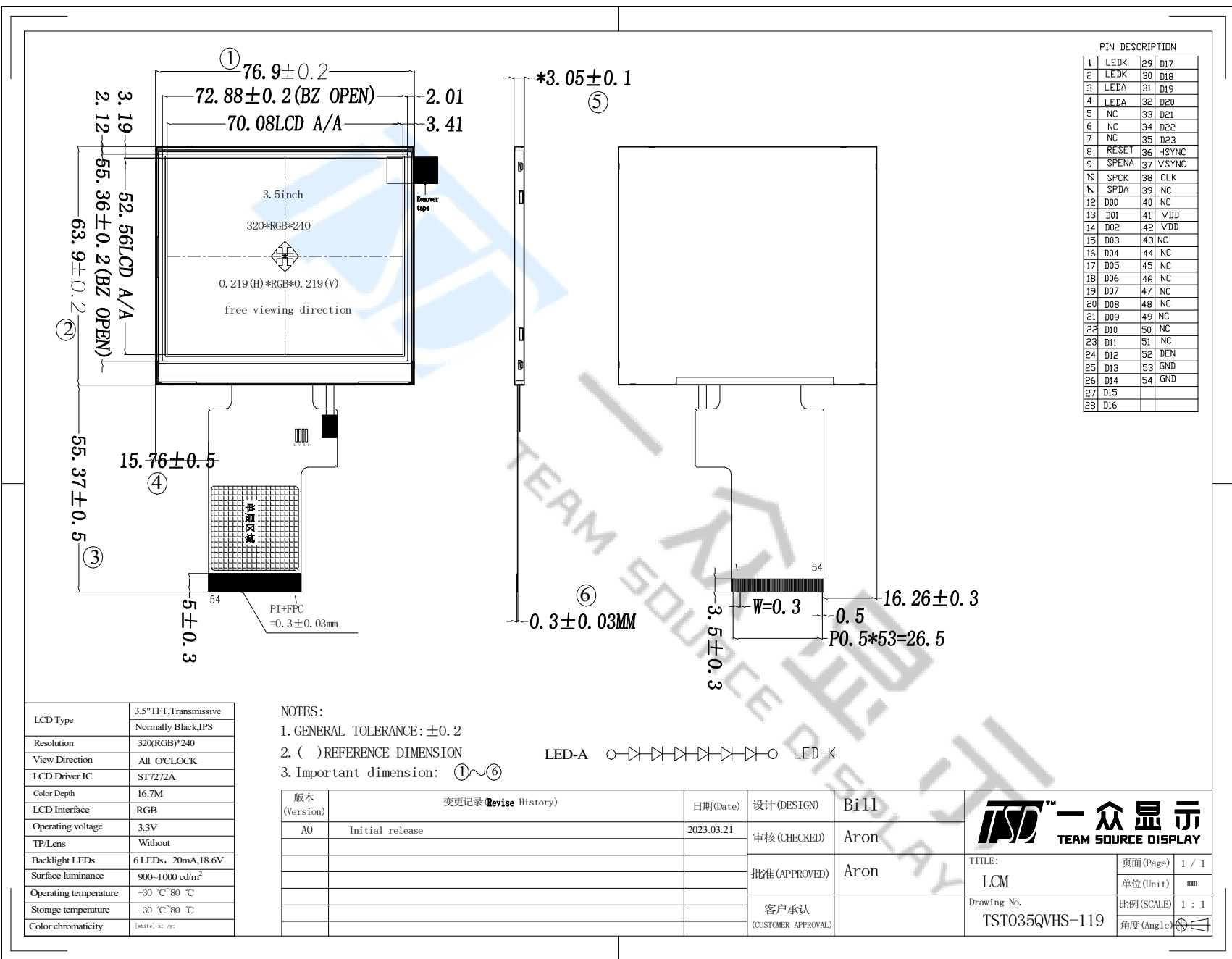

### 3 Interface description

#### 3.1 LCM interface description

Pin No.	Symbol	Description
1-2	LEDK	Cathode of LED backlight.
3-4	LEDA	Anode of LED backlight.
5-7	NC	Not Connection
8	RESET	System reset pin. - An active low pulse at this pin will reset the IC, Connect to VCC in normal operation
9	CS/NC	CS : Chip select pin /Not Connection
10	SCK/NC	Serial clock input/Not Connection
11	SDA/NC	Data input/output pin in serial interface/Not Connection
12~19	B0-B7	Blue Data bus:B0~B7
20~27	G0-G7	Green Data bus:G0~G7
28~35	R0-R7	Red Data bus:R0~R7
36	HSYNC	Line Synchronization input
37	VSYNC	Frame/Ram Write Synchronization input
38	DCLK	Dot-clock signal and oscillator source.
39-40	NC	Not Connection
41-42	VDD	Power supply for digital voltage
43-47	NC	Not Connection
48	X-	Not Connection
49	Y-	Not Connection
50	X+	Not Connection
51	Y+	Not Connection
52	DE	Display enable pin from controller.
53-54	GND	Ground.

## 4 LCM Interface Timing and POWER ON/OFF SEQUENCE

### 4.1 Reset Timing

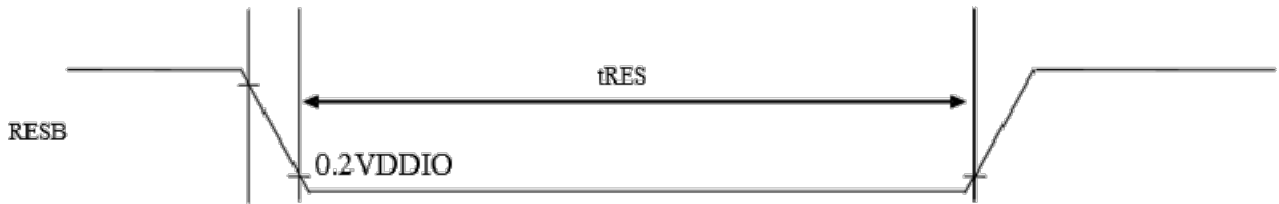

Signal	Parameter	Min	Typ	Max	Unit
nRES	Reset pulse duration	15	-	-	us

## 4.2 RGB interface Timing

### 4.3.1 SYNC Mode

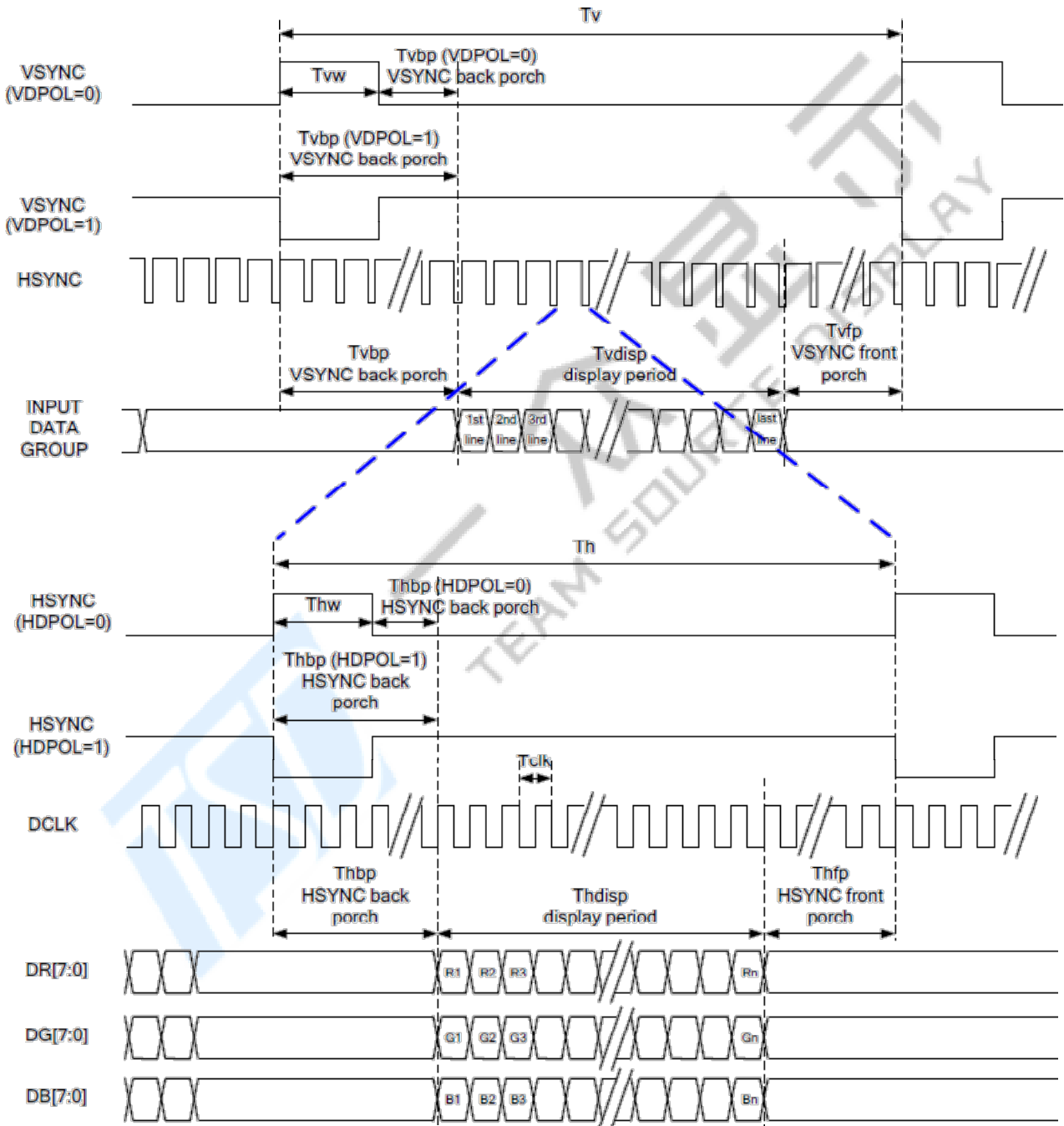

### 4.3.2 SYNC-DE Mode

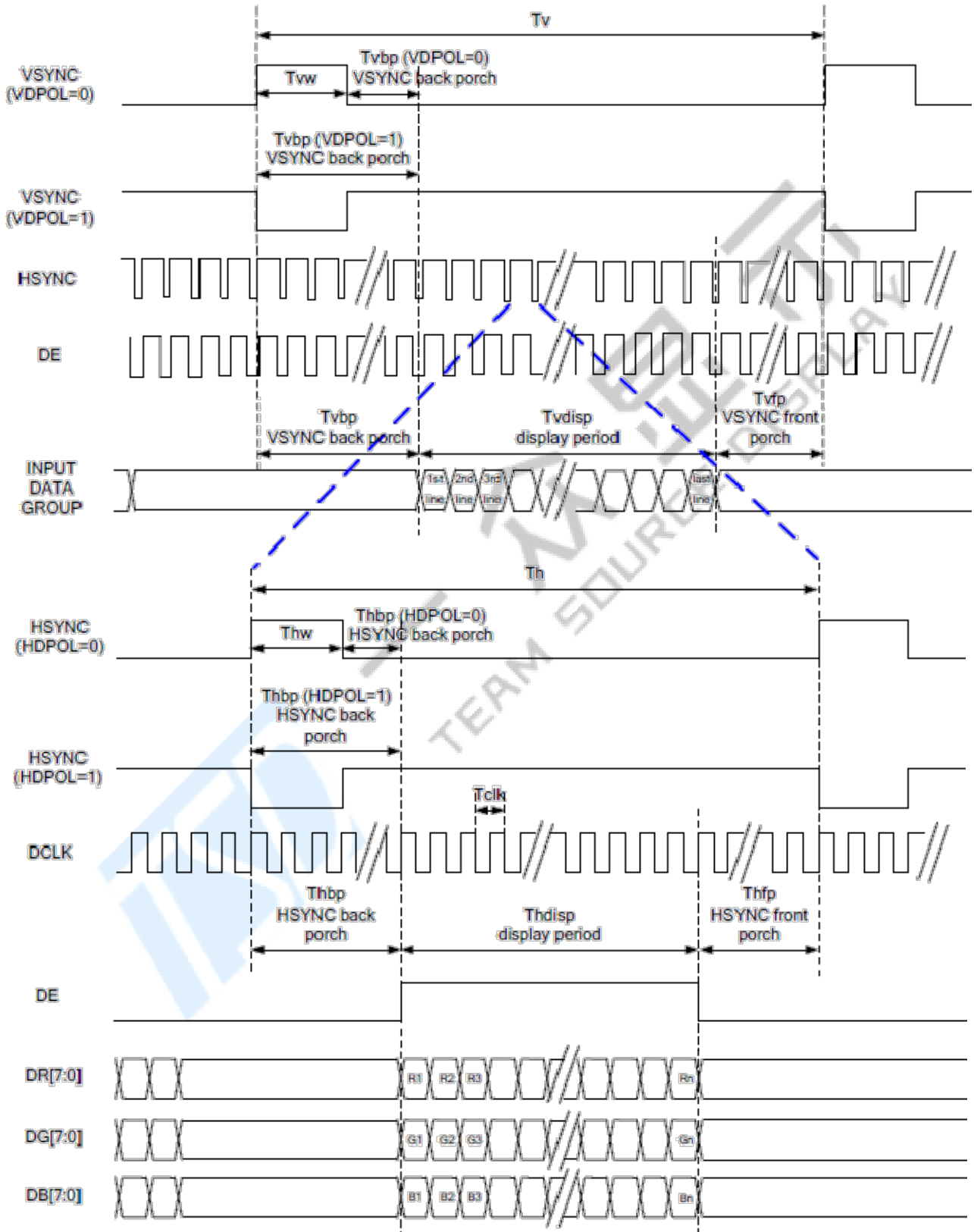



### 4.3.3 DE Mode

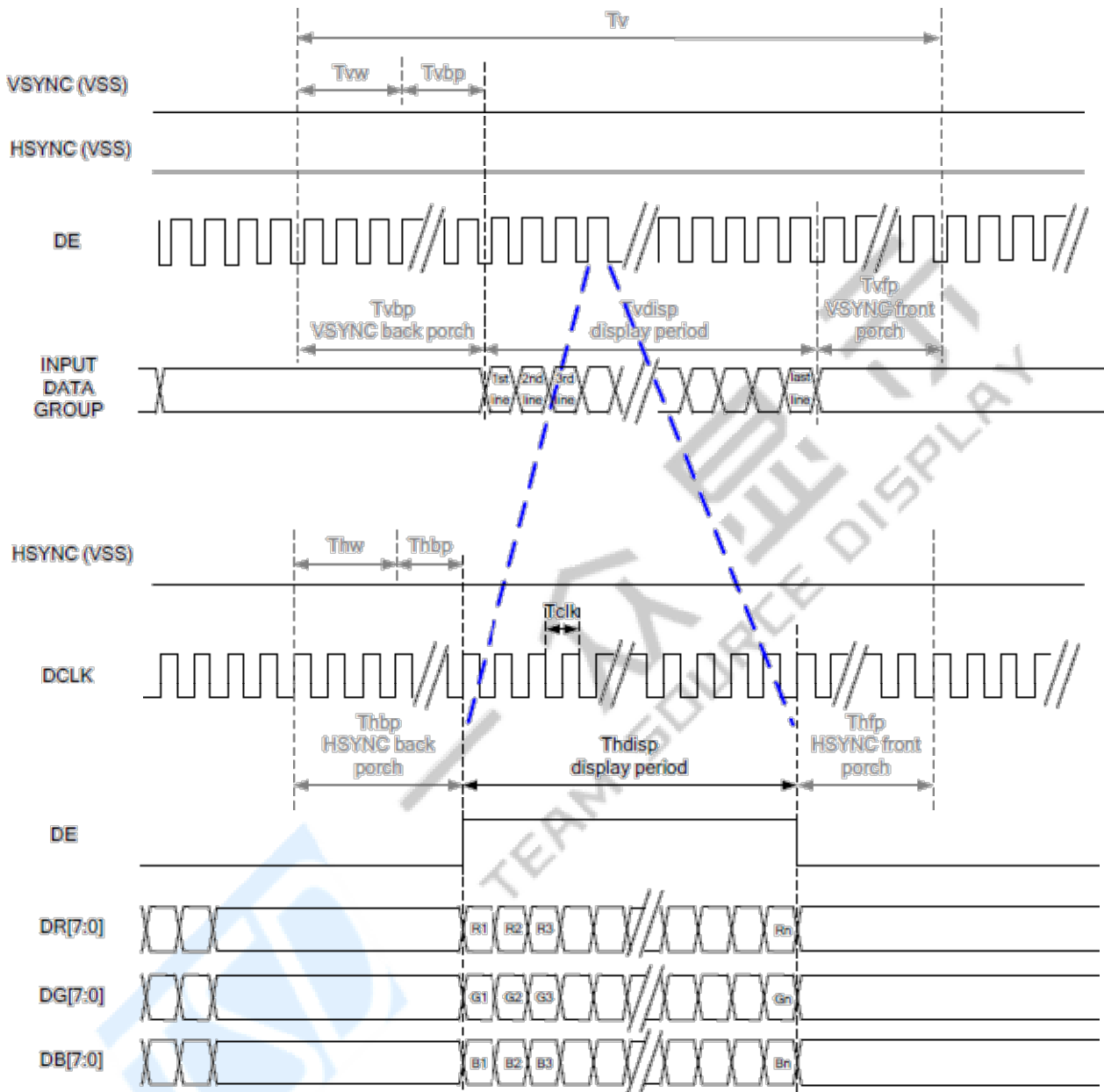

RGB Mode Selection Table	DCLK	HSYNC	VSYNC	DE
SYNC - DE Mode	Input	Input	Input	Input
SYNC Mode	Input	Input	Input	GND
DE Mode	Input	GND	GND	Input

Note: "Input" means these signals are driven by host side.

### 4.3.4 RGB input timing table

Characteristics	Symbol	Min.		Typ.		Max.		Unit
		24 bit	8 bit	24 bit	8 bit	24 bit	8 bit	
DOTCLK Frequency	fDOTCLK	-	-	6.5	19.5	10	30	MHz
DOTCLK Period	tDOTCLK	100	33.3	154	51.3	-	-	ns
Horizontal Frequency (Line)	fH	-		14.9		22.35		KHz
Vertical Frequency (Refresh)	fV	-		60		90		Hz
Horizontal Back Porch	tHBP	-	-	68	204	-	-	tDOTCLK
Horizontal Front Porch	tHFP	-	-	20	60	-	-	tDOTCLK
Horizontal Data Start Point	tHBP	-	-	68	204	-	-	tDOTCLK
Horizontal Blanking Period	tHBP + tHFP	-	-	88	264	-	-	tDOTCLK
Horizontal Display Area	HDISP	-	-	320	960	-	-	tDOTCLK
Horizontal Cycle	Hcycle	-	-	408	1224	450	1350	tDOTCLK
Vertical Back Porch	tVBP	-		18		-		Lines
Vertical Front Porch	tVFP	-		4		-		Lines
Vertical Data Start Point	tVBP	-		18		-		Lines
Vertical Blanking Period	tVBP + tVFP	-		22		-		Lines
Vertical Display Area	NTSC	-		240		-		Lines
	PAL			280(PALM=0)				
	PAL			288(PALM=1)				
Vertical Cycle	NTSC	-		262		350		Lines
	PAL			313				

## 4.3 POWER ON/OFF SEQUENCE

### 4.3.1 Power On Sequence

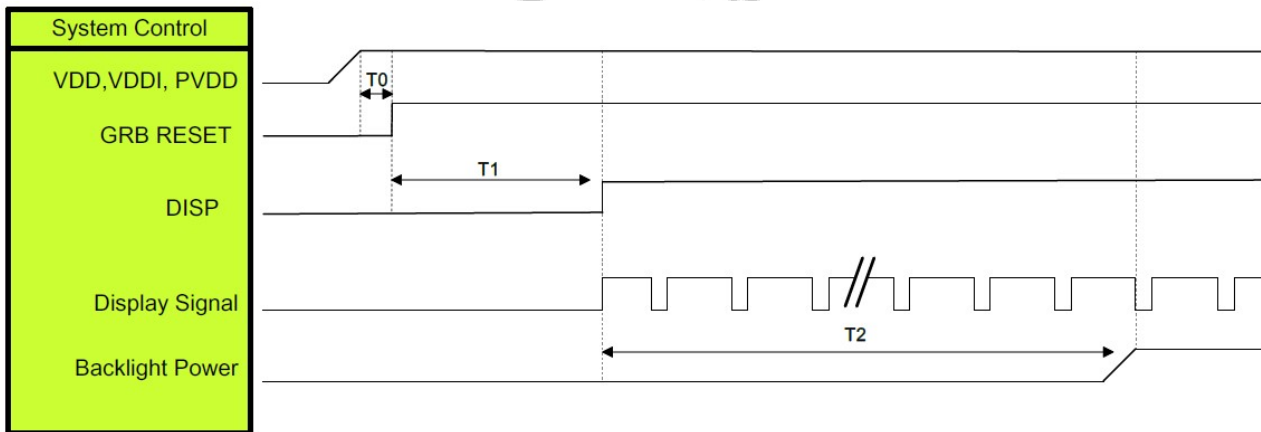

Symbol	Description	Min. Time	Unit
T0	System power stability to GRB RESET signal	0	ms
T1	GRB RESET= “High” to DISP=” High”	10	ms
T2	Display Signal output to Backlight Power on	250	ms

Note: Display signal: DCLK; VSYNC; HSYNC; DE; DR[7:0]; DG[7:0]; DB[7:0]

### 4.3.2 Power Off Sequence

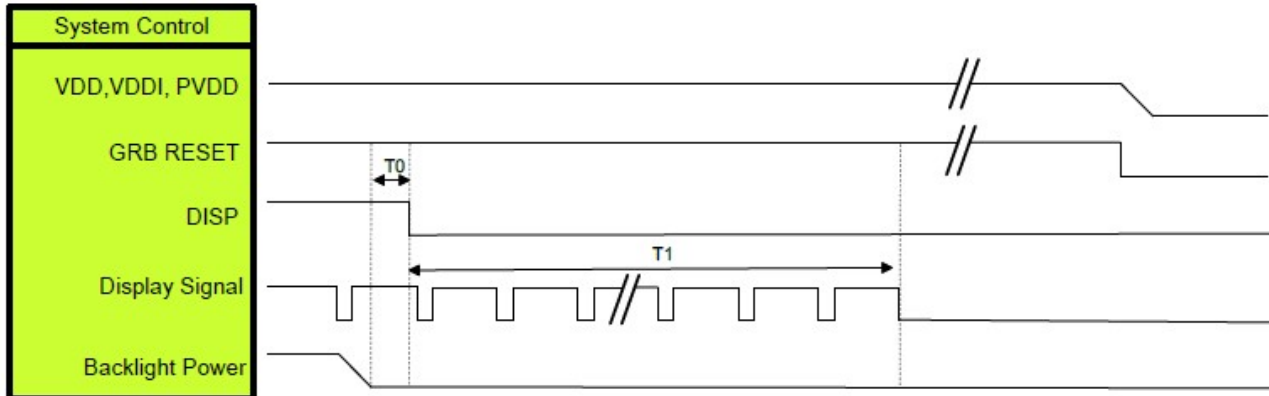

Symbol	Description	Min. Time	Unit
T0	Backlight Power off to DISP=" Low"	5	ms
T1	DISP=" Low" to IC internal voltage discharge complete	80	ms

Note: Display signal: DCLK; VSYNC; HSYNC; DE; DR[7:0]; DG[7:0]; DB[7:0]

## 5 Absolute Maximum Ratings

PARAMETER	SYMBOL	MIN	MAX	UNIT
Supply Voltage (Analog)	VDD	-0.3	4.0	V
Logic signal voltage(I/O)	VDDI	-0.3	4.0	V
Operating Temperature	Top	-30	80	° C
Storage Temperature	Tst	-30	80	° C
Operating Ambient Humidity	Hop	10	90%(Max 60° C)	RH

## 6 Electrical Characteristics

PARAMETER	SYMBOL	MIN	TYP	MAX	UNIT
Analog operating voltage	VDD	3.0	3.3	3.6	V
Logic operating voltage	VDDI	-	-	-	V
Input Current	IDD	-	TBD	-	mA
Input Voltage ' H ' level	VIH	0.7VDDI	-	VDDI	V
Input Voltage ' L ' level	VIL	DGND	-	0.3VDDI	
Output Voltage ' H ' level	VOH	VDDI-0.4	-	VDDI	
Output Voltage ' L ' level	VOL	DGND	-	DGND+0.4	

## 7 Backlight Characteristics

ITEM	SYMBOL	MIN	TYP	MAX	UNIT
Voltage for LED backlight	V <sub>f</sub>	-	18.6	-	V
Current for LED backlight	I <sub>f</sub>	-	20	-	mA
Uniformity	Avg	80	-	-	%
LED Life Time	-	30000	40000	-	

Note:

1. The LED life time is defined as the module brightness decrease to 50% original brightness at Ta=25°C, 60%RH ±5 %.
2. The life time of LED will be reduced if LED is driven by high current, high ambient temperature and humidity conditions.
3. Typical operating life time is an estimated data.
4. Permanent damage to the device may occur if maximum values are exceeded or reverse voltage is loaded .Functional operation should be restricted to the conditions described under normal operating conditions.

## 8 LCD Optical specifications

Item	Symbol	Condition	Specification			Unit	Remark
			Min	Typ	Max		
Response time (By Quick)	Tr+Tf	-	-	30	40	ms	Note 2
Contrast ratio	CR	-	640	800	-	-	Note 3
Surface luminance	Lv	$\theta=0^\circ$	900	-	1000	cd/m <sup>2</sup>	Note 4
Luminance uniformity	Yu	$\theta=0^\circ$	80	-	-	%	Note 6
Viewing angle	Top	$CR \geq 10$	70	80	-	Deg.	Note 7
	Bottom	$CR \geq 10$	70	80	-		
	Left	$CR \geq 10$	70	80	-		
	Right	$CR \geq 10$	70	80	-		
CIE(x,y) chromaticity	Wx	$\theta=0^\circ$	0.287	0.317	0.347		Note 5
	Wy		0.309	0.339	0.369		

Note 1: Ambient temperature = 25°C.

Note 2: Definition of response time:

The output signals of TRD-100 are measured when the input signals are changed to “White” (falling time) and from “White” to “Black” (rising time), respectively. The interval is between the 10% and 90% of amplitudes. Refer to figure as below.

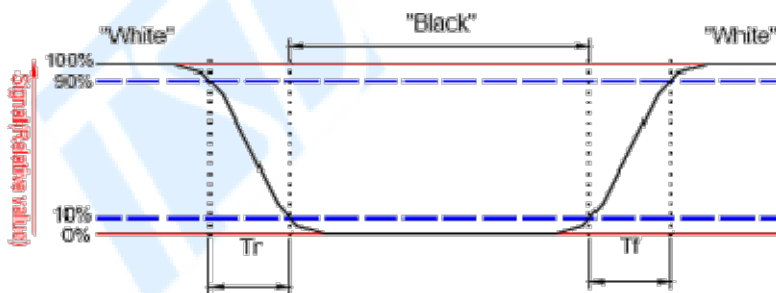

Note 3: Definition of contrast ratio:

Contrast ratio is calculated by the following formula.

$$\text{Contrast ratio (CR)} = \frac{\text{Brightness on the "white" state}}{\text{Brightness on the "black" state}}$$

Measured at the center area of the LCD.

Note 4: Definition of surface luminance

Surface luminance is the luminance with all pixels displaying white

Note 5: For contrast ratio, Surface Luminance, Luminance uniformity and CIE, the testing data is based on TOPCON's BM-7

photo detector or compatible.

Size :  $S \leq 4.3''$  (see Figure A B)

H,V : Active area

Light spot size=7.7mm (BM-7)50cm distance or compatible distance from the LCD surface to detector lens.

test spot position : see Figure B.

measurement instrument : TOPCON' s luminance meter BM-7 or compatible.

Size :  $4.3 < S \leq 12.3''$  (see Figure A C)

H,V : Active area

Light spot size=7.7mm (BM-7)50cm distance or compatible distance from the LCD surface to detector lens.

test spot position : see Figure C.

measurement instrument : TOPCON' s luminance meter BM-7 or compatible.

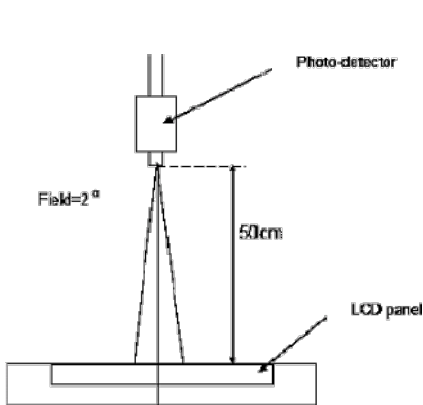

Figure A

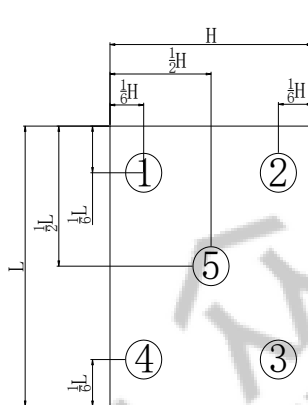

Figure B

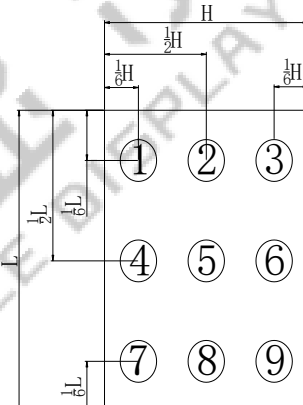

Figure C

Note 6:Definition of Luminance Uniformity

Active area is divided into 5 or 9 measuring areas,Every measuring point is placed at the center of each measuring area

Bmax: The measured maximum luminance of all measurement position.

Bmin: The measured minimum luminance of all measurement position.

**Luminance Uniformity (Yu)= (Bmin/Bmax)x100%**

Note 7: Definition of viewing angle

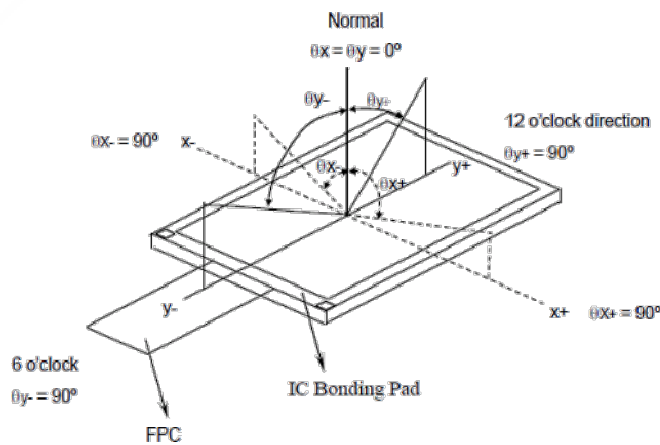

## 9 RELIABILITY TEST

### 9.1 Test condition

NO.	TEST ITEM	TEST CONDITION	INSPECTION AFTER TEST
1	High Temperature Storage	80±2°C/96 hours	Inspection after 2~4 hours storage at room temperature and humidity. The condensation is not accepted. The sample shall be free from defects:  1. Air bubble in the LCD 2. Seal leak 3. Non-display 4. Missing segments 5. Glass crack
2	Low Temperature Storage	-30±2°C/96 hours	
3	High Temperature Operating	80±2°C/96 hours	
4	Low Temperature Operating	-30±2°C/96 hours	
5	Temperature Cycle	-30±2°C ~ 25~ 80± 2°C × 10 cycles (30 min.) (5min.) (30min.)	
6	Damp Proof Test	60°C ±5°C × 90%RH/96 hours	
7	Vibration Test	Frequency 10Hz~55Hz Stroke: 1.5mm Sweep: 10Hz~150 Hz~10Hz 2 hours For each direction of X, Y, Z	
8	Packing Drop Test	Height: 50 cm 1 corner, concrete floor	
9	Electrostatic Discharge Test	C=150pF, R=330 Ω Air: ±8KV 150pF/330Ω 30 times Contact: ±4KV,20 times	
10	Image Sticking	25°C,60%RH (ref.to Remark(1))/30 minutes	

**Remark (1):** Switch the image to Grey 127 after displaying the 5\*8 chess pattern for **30 minutes**, the afterimage disappears within **10 minutes**.

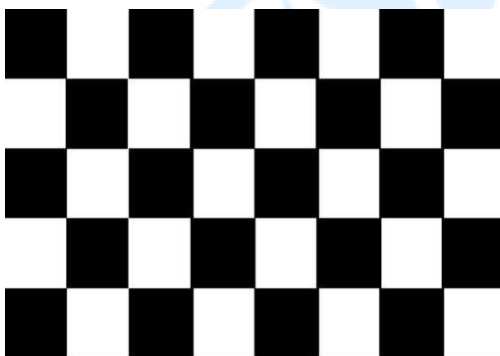

5\*8 chess pattern



Gray127

## 9.2 About Image Sticking

### 9.2.1 What is Image Sticking?

If you remain a fixed image on LCD Display for a long period of time, you may experience a phenomenon called Image Sticking. Image Sticking - sometimes also called “image retention” or “ghosting” - is a phenomenon where a faint outline of a previously displayed image remains visible on the screen when the image is changed. It can occur at variable levels of intensity depending on the specific image makeup, as well as the amount of time the core image elements are allowed to remain unchanged on the screen. In POS applications, for example, a button menu which remains fixed, or in which the “frame” elements (core image) remain fixed and the buttons may change, may be susceptible to image sticking. It is important to note that if the screen is used exclusively for this application, the user may never notice this phenomenon since the screen never displays other content. It is only when an image other than the “retained” image is shown on the screen that this issue becomes evident. Image sticking is different that the “burn-in” effect commonly associated with phosphor based devices.

### 9.2.2 What causes Image Sticking?

Image sticking is an intrinsic behavior of LCD displays due to the susceptibility to polarization of the interior materials (liquid crystals) when used under static, charged conditions (continuously displaying the same image). The individual liquid crystals in an LCD panel have unique electrical properties. Displaying a fixed pattern - such as the POS menu described above - over prolonged periods can cause a parasitic charge build-up (polarization) within the liquid crystals which affects the crystals’ optical properties and ultimately prevents the liquid crystal from returning to its normal, relaxed state when the pattern is finally changed. This effect takes place at a cellular level within the LCD, and the effect can cause charged crystal alignment at the bottom or top of a crystal cell in the “z” axis, or even crystal migration to the edges of a cell, again based on their polarity. These conditions can cause image sticking over an entire area, or at boundaries of distinct color change respectively. In either case, when the liquid crystals in the pixels and sub-pixels utilized to display the static image are polarized such that they can not return fully to their “relaxed” state upon deactivation, the result is a faint, visible, retained image on the panel upon presentation of a new, different image. The actual rate of image retention depends on variation factors such as the specific image, how long it is displayed unchanged, the temperature within the panel and even the specific panel brand due to manufacturing differences amongst panel manufacturers.

### 9.2.3 How to Avoid Image Sticking?

- Try not to operate the LCD with a “fixed” image on the screen for more than 2 hours.
- If you are operating the monitor in an elevated temperature environment and with a displayed image which is contrary to the recommendations in “For Software Developers” below, image stick can occur in as little as 30 minutes. Adjust your screen saver settings accordingly.
- Power down the unit during prolonged periods of inactivity such as the hours a store is closed or a shift during which the piece of equipment isn’t used.
- Use a screensaver with a black or medium gray background that is automatically set to come on if the device is inactive for more than 5-10 minutes.
- Avoid placing the monitor in poorly ventilated areas or in areas that will create excess heat around the monitor for software developers.
- In defining the icons, buttons, or windows in the screen, try to utilize block patterns instead of distinct lines as borders for dividing the display into distinct areas.

- If it is necessary to display a static image, try to use colors that are symmetric to the middle grey level at the boundary of two different colors, and slightly shift the borders line once in a while.
- Try to utilize medium gray hues for those areas that will have prolonged display times or remain static as other menu elements change.

### 9.2.4 How to Fix the Image Sticking?

Unlike the usually irreversible “burn-in” effects commonly associated with direct view phosphor display devices such as CRTs, an image retained on an LCD display can be reversed – often to a point of total invisibility. However, the severity of the underlying causes (as described above) of the image retained on a specific display, as well as the variation factors (see “For Software Developers” above) under which the retained image was created, will dictate the final level of retention reversal. One way to erase a retained image on a panel is to run the screen (monitor “on”) in an “all black” pattern for 4-6 hours. It is also helpful to do this in an elevated temperature environment of approximately 35° to 50° C. Again, utilizing a dynamic screen saver with an all black background during prolonged idle display periods is a good way to avoid image retention issues.

### 9.2.5 Is Image Sticking Covered by TSD RMA Warranty?

Image sticking is a phenomenon inherent to LCD Display technology itself, and as such, the occurrence of this “ghosting” effect is considered normal operation by the manufacturers of the LCD display modules which are integrated into today’s monitor solutions. TSD does not warrant any display against the occurrence of image sticking. We strongly advise that you follow the operating recommendations listed above to avoid the occurrence of this phenomenon.

## 9.3 Others

1. Issues that are not defined in this document shall be discussed and agreed with both parties. (Customer and supplier)
2. Unless otherwise agreed upon in writing, the criteria shall be applied to both parties. (Customer and supplier)

## 10 Suggestions for using LCD modules

### 10.1 Handling of LCM

1. The LCD screen is made of glass. Don't give excessive external shock, or drop from a high place.
2. If the LCD screen is damaged and the liquid crystal leaks out, do not lick and swallow. When the liquid is attach to your hand, skin, cloth etc, wash it off by using soap and water thoroughly and immediately.
3. Don't apply excessive force on the surface of the LCM.
4. If the surface is contaminated, clean it with soft cloth. If the LCM is severely contaminated, use Isopropyl alcohol/Ethyl alcohol to clean. Other solvents may damage the polarizer. The following solvents is especially prohibited: water , ketone Aromatic solvents etc.
5. Exercise care to minimize corrosion of the electrode. Corrosion of the electrodes is accelerated by water droplets, moisture condensation or a current flow in a high-humidity environment.
6. Install the LCD Module by using the mounting holes. When mounting the LCD module make sure it is free of twisting, warping and distortion. In particular, do not forcibly pull or bend the I/O cable or the backlight cable.
7. Don't disassemble the LCM.
8. To prevent destruction of the elements by static electricity, be careful to maintain an optimum work environment.
  - Be sure to ground the body when handling the LCD modules.



- Tools required for assembling, such as soldering irons, must be properly grounded.
  - To reduce the amount of static electricity generated, do not conduct assembling and other work under dry conditions.
  - The LCD module is coated with a film to protect the display surface. Exercise care when peeling off this protective film since static electricity may be generated.
9. Do not alter, modify or change the the shape of the tab on the metal frame.
  10. Do not make extra holes on the printed circuit board, modify its shape or change the positions of components to be attached.
  11. Do not damage or modify the pattern writing on the printed circuit board.
  12. Absolutely do not modify the zebra rubber strip (conductive rubber) or heat seal connector
  13. Except for soldering the interface, do not make any alterations or modifications with a soldering iron.
  14. Do not drop, bend or twist LCM.

## 10.2 Storage

1. Store in an ambient temperature of 5 to 45 °C, and in a relative humidity of 40% to 60%. Don't expose to sunlight or fluorescent light.
2. Storage in a clean environment, free from dust, active gas, and solvent.
3. Store in antistatic container.

## 11 Limited Warranty

1. Our warranty liability is limited to repair and/or replacement. We will not be responsible for any consequential loss.
2. If possible, we suggest customer to use up all LCD modules as soon as possible. If the LCD module storage time over twelve months, we suggest to recheck it before being used.
3. Any product issues must be feedback to TSD within 12 months since delivery, otherwise, we will not be responsible for the subsequent or consequential events.